

密闭型低温冷却液循环泵

SEALED LOW-TEMPERATURE COOLANT CIRCULATION PUMP

用户手册 User's Guide

! 注意 使用本产品时,请您先仔细阅读使用说明书,再正确操作。
请妥善保管好本手册,以便日后查阅。

! CAUTION Before using this product,read carefully these
instructions for correct operation.

Keep the User's Guide in a secure place for
future reference.

Content

1	Product overview.....	1
1.1	Foreword.....	1
1.2	Safety.....	1
1.2.1	User qualification.....	1
1.2.2	Proper use.....	1
1.2.3	Improper use.....	1
1.2.4	Warning sign used in the instruction manual.....	2
1.2.5	Equipment-related hazards.....	3
1.2.6	Other hazards.....	4
1.2.7	Security measures.....	4
1.3	Device Introduction.....	4
1.4	Device configuration.....	5
1.5	Control panel description.....	7
2	Unpacking and installation.....	8
2.1	Unpacking.....	8
2.2	Installation.....	9
3	Operation.....	11
3.1	Selection of refrigerant.....	11
3.2	Power connection.....	12
3.3	Control panel operation.....	13
3.4	Communication connection.....	14
3.5	Wiring diagram.....	15
3.6	The error displaying.....	16
4	Maintenance and management.....	17
4.1	Management.....	17
4.2	Maintenance of cooling system.....	17
4.3	Maintenance requirements.....	19
5	Parameters.....	19
6	Common fault analysis reasons and treatment.....	22
7	Precautions.....	23
8	Warranty statement.....	24



Product overview

1.1 Foreword

Thank you for using the "sealed low-temperature coolant circulation pump". This operating manual describes the installation, use, maintenance and maintenance of the sealed low-temperature coolant circulation pump. Please read the instruction carefully before using the equipment.

1.2 Safety

This chapter describes the safety rules and regulations involved in the installation and use of the "sealed low-temperature coolant circulation pump". Under the premise of mastering the relevant warning signs, users should strictly abide by the operating procedures to ensure the safety of equipment and life and avoid accidents.

1.2.1 User qualification

The operator of the "sealed low-temperature coolant circulation pump" should have practical operating experience and be able to grasp the requirements in this manual; otherwise, it should be used under the guidance of personnel with corresponding technical ability.

1.2.2 Proper use

The "sealed low-temperature coolant circulation pump" is required to be installed indoors and can be used as a cryogenic reaction bath alone or in combination with other equipment to provide the temperature conditions required for experiments or production.

Application range:

- (a) It can be used to cool flasks, beakers, test tubes, etc;
- (b) It can be used for cooling and cooling of glass reactors and fermentation tanks;
- (c) It can be used for rotary evaporator, vacuum frozen drying oven and other cooling;









1.2.3 Improper use

Failure to follow the instructions in the instruction manual is improper use. The damage caused by improper use shall be borne by the user.

It is prohibited to use under the following conditions:

- (A) explosive gas environment or explosive dust environment;
- (B) Locations where the power supply does not meet the requirements;
- (C) Strong magnetic field environment and corrosive environment;







1.2.4 Warning signs used in the instruction manual

Sign	Meaning
 Danger	Danger means that the situation is very dangerous and will result in death or serious injury.
 Warning	Warning, Indicates a dangerous situation that could result in death or serious injury.
 Note	Pay attention to The situation is dangerous and may result in injury.
 Be careful of frostbite	Be careful of frostbite, When the temperature is low, do not touch, beware of frostbite.
 Prohibited in the rain	Prohibited in the rain, No splashing in the rain.
 Pay attention to high temperature	Pay attention to high temperature, When the liquid temperature is high, do not touch and move, be careful of scald.
 Beware of fire	Beware of a fire, The machine is equipped with heating device. No one is allowed to work.
 Note	Pay attention to Please wear protective equipment, or you may cause personal injury.
Prompt	prompt, Indicates a situation that may cause damage to the equipment.

Note: All warning signs require special attention

1.2.5 Equipment-related hazards

Please note the following safety tips:

 Note	Dangerous, do not use in explosive gas environment or explosive dust environment
 Prohibited in the rain	Do not rain, do not use in outdoor environment. Rain, splashing will lead to electrical shell, causing casualties
 warning	<ul style="list-style-type: none"> ● Be sure to connect the power supply specified on the equipment nameplate; ● Implement equipotential bonding of the equipment, and the internal grounding connection wire is not allowed to be dismantled; ● Before opening the equipment shell for maintenance and repair, be sure to disconnect the power supply of the equipment, and it can be operated after 5s to ensure that the residual voltage is released to a safe value to avoid electric shock; ● When the device casing is not installed in place, please do not put the device into use to prevent electric shock; ● When the refrigerant leaks, it shall be handled in accordance with the provisions of GB/T16483-2008 "Contents and Project Order of Chemical Safety Data Sheets". When there is a lot of refrigerant leakage, there is a risk of causing anesthesia and even suffocation of the personnel on site ● When it is confirmed that the refrigerant is insufficient, stop using it and ask a professional to replenish the refrigerant;
 Note	<ul style="list-style-type: none"> ● If there is any abnormal situation in the process of using the equipment, please disconnect the power supply first and then enter the fault troubleshooting. Contact professional maintenance personnel as required; ● When cleaning, maintenance, maintenance should wear good labor protection gloves, guard against the condenser fin injury hand; ● Refrigerant discharge: in order to prevent the discharge of refrigerant injury, it is recommended to be in the safe temperature range(5-40℃) for discharge.
 Be careful of frostbite	Liquid out, liquid return pipeline and valve may be low temperature, beware of frostbite.
 Pay attention to	Do not go near the rotating parts to prevent injuries.
Prompt	<ul style="list-style-type: none"> ● please do not use in high temperature, humid environment. Otherwise, the positive of the device will be affected Normal operation and service life; ● clean the condenser regularly. The refrigeration capacity of the equipment when the condenser is clogged with dirt Decrease and increase power consumption; ● good ventilation should be maintained around the equipment; ● some space should be reserved near the equipment. Items cannot be placed within 0.7m; ● Selection of refrigerant: please select the refrigerant according to the temperature range and equipment component materials Appropriate refrigerant carrier; ● no idling circulation pump; Please do not press too hard on the equipment shell.

1.2.6 Other hazards

 Warning	<ul style="list-style-type: none"> ● The presence of corrosive materials such as acid and alkali vapors around the equipment will damage the equipment insulation and affect Component performance and service life; ● The used coolant should not be in contact with food, medicine, tobacco, etc. to avoid personal injury.
--	---

1.2.7 Security measures

	<ul style="list-style-type: none"> ● Wear personal protective equipment when operating this equipment, such as wearing protective glasses and gloves, and wearing protective clothing.
---	---

1.3 Device Introduction

With its own refrigeration, circulation and temperature control system, the sealed low-temperature coolant circulation pump provides low-temperature conditions in a certain temperature range to meet the requirements of scientific research and production tests. The schematic diagram of its use is shown in Figure 1.3.1.

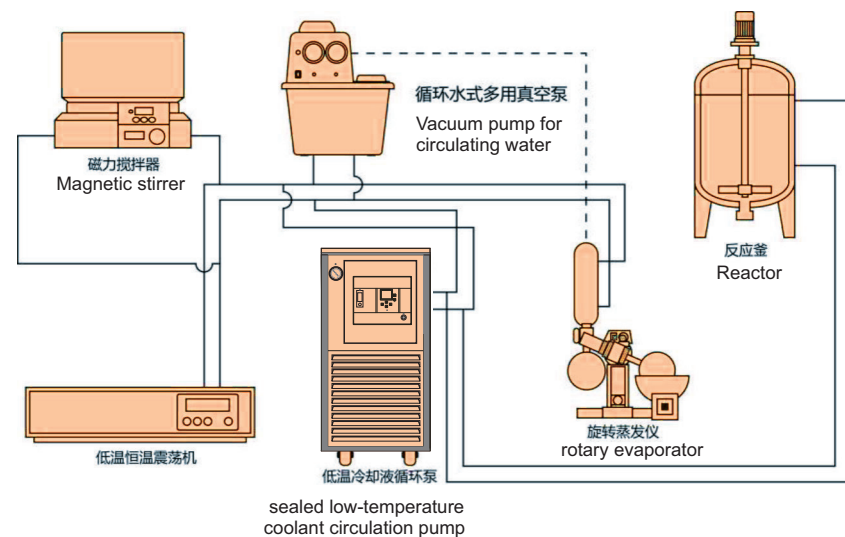
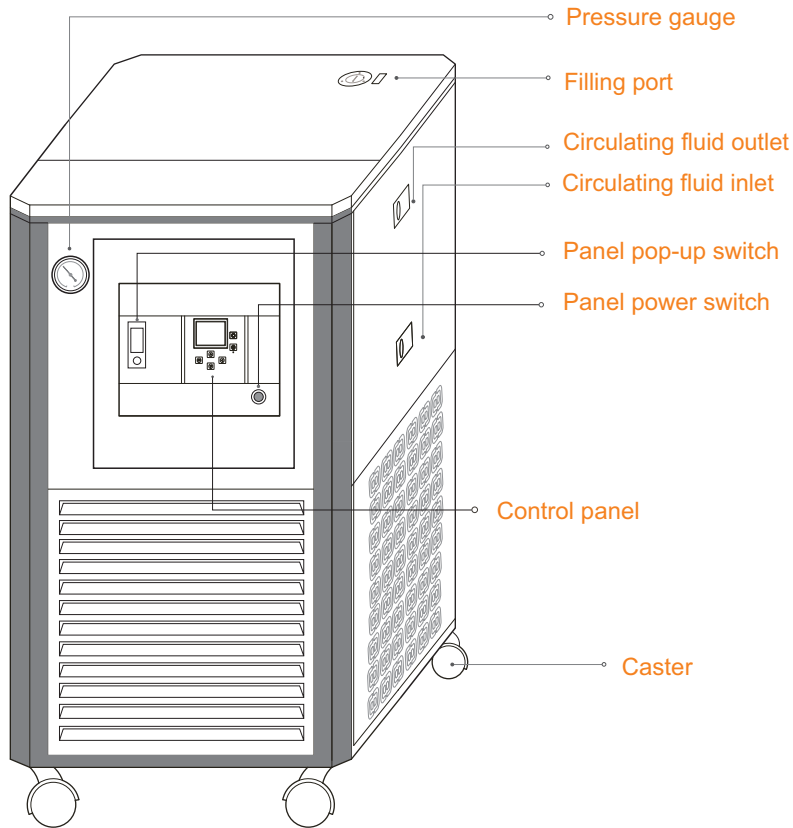
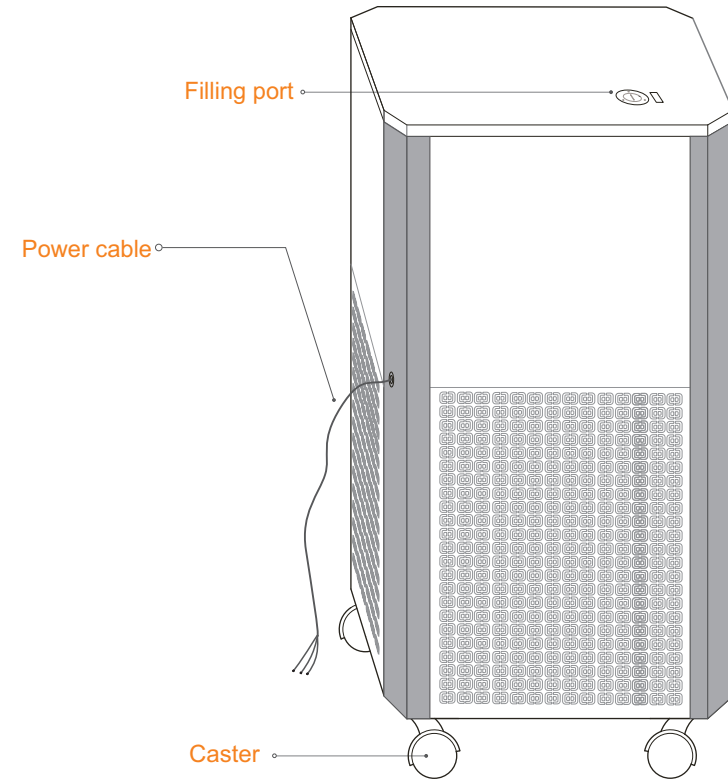

Figure 1.3.1

1.4 Device configuration



Front figure 1.4.1



Back figure 1.4.2

1.5 Control panel description

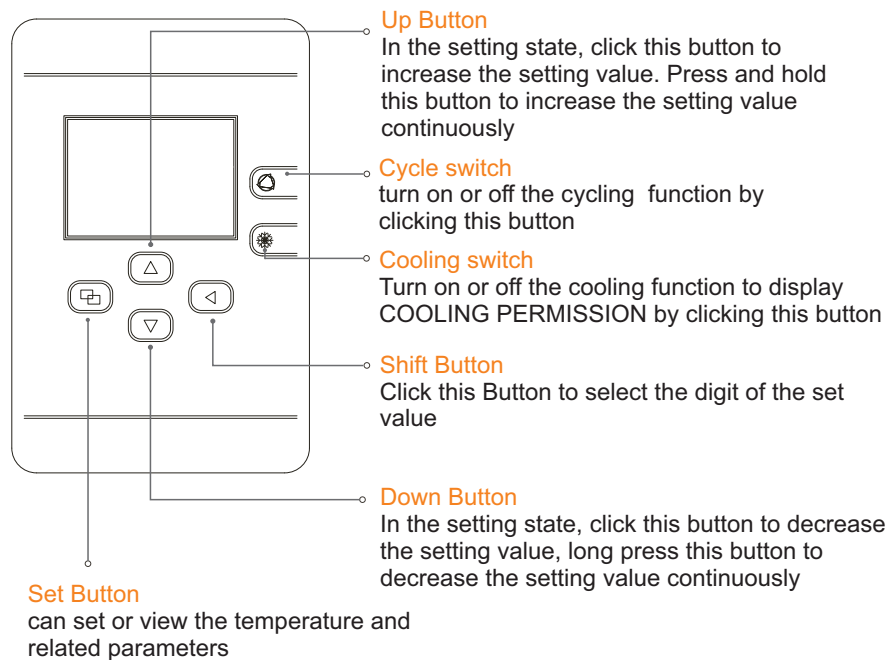

Figure 1.5.1

2 Unpacking and installation

2.1 Unpacking

(1) Open the outer packing box, take out and read the product instruction manual carefully, check whether the equipped components are complete and the appearance of the device is damaged according to the packing list.

(2) Place the equipment steadily, and put it on for more than 12h before starting and debugging.

(3) Maintain good ventilation and the ambient temperature should not exceed 35°C. Note: The vents of the device body are strictly forbidden to block!

(4) Wrap a proper amount of PTFE raw tape clockwise at the threaded interface of the valve, and tighten it with the refrigerant liquid inlet and liquid outlet of the equipment.

(5) When the user needs external circulation, connect the cold equipment for hose connection to the outlet and return (inlet) valve interfaces.

(6) Connect the piping of the circulation system according to the on-site installation schematic; the refrigeration host and the refrigerant buffer storage tank should be placed on a suitable concrete foundation, level the machine, and fix it after leveling.

(7) If liquid is splashed or spilled on the device casing, it should be wiped clean to ensure that all components are intact before being put into use.

2.2 Installation

- 1 Tear off the packaging film
Unpack
Tear off the packaging film

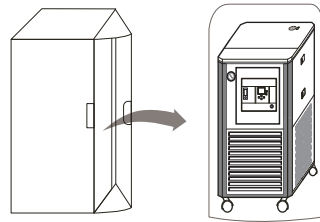

- 2 Remove the dust plug
Remove the dust plug from the inlet and outlet

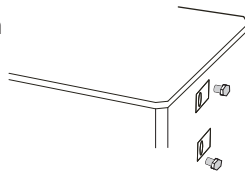

- 3 Installation of connecting pipes and parts (See the next page for parts installation)

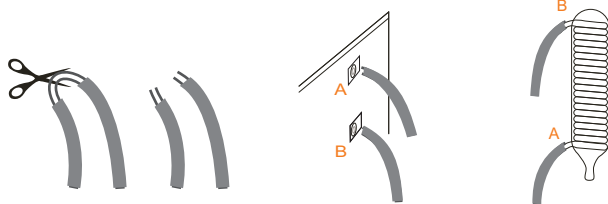

- Remove the connecting pipe and cut evenly into two pieces → Install the connecting pipe to the machine → Install the connecting pipe to the condenser

- 4 Add circulating fluid
Open the top metal cover and inject the circulating fluid
Circulating fluid (the circulating fluid should not pass through the pipeline)

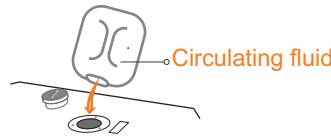

- 5 Connect the power supply

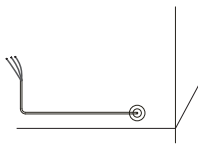

Figure 2.2.1

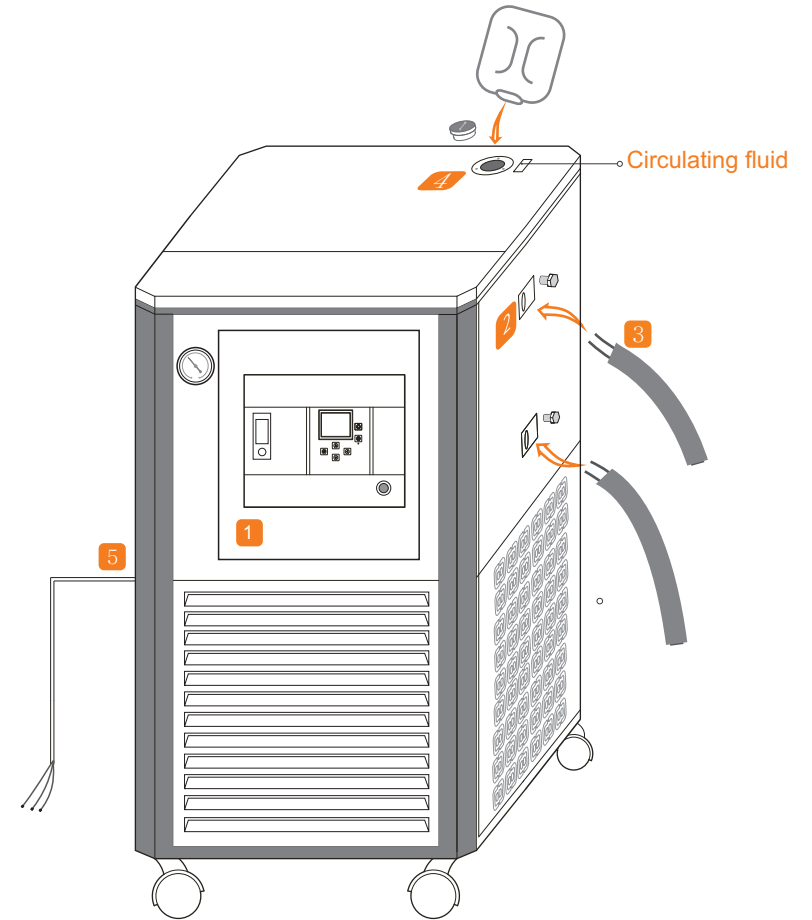

Figure 2.2.2

3 operation

3.1 Selection of refrigerant

The expected target temperature is determined by the type of refrigerant used in the sealed low-temperature coolant circulation pump. The coolant is non-toxic and non-corrosive, and its viscosity is $\leq 22 \text{ mPa}\cdot\text{s}$ at the lowest working temperature.

1. When the use temperature is above 10°C , it is recommended to use distilled water or deionized water as the coolant.

2. When the operating temperature is $-30^\circ\text{C} \sim 10^\circ\text{C}$, it is recommended to use the ethylene glycol aqueous solution described in Table 3.1. The minimum operating temperature should be 10°C above the freezing point; or 99% (mass fraction) ethanol.

Table 3.1 Correspondence between the ratio of ethylene glycol aqueous solution and freezing point

(%)mass fraction	15	25	30	40	50	55
($^\circ\text{C}$)Freezing point ($^\circ\text{C}$)	-5	-10	-15	-22	-23	-40

3. When the use temperature is $-80^\circ\text{C} \sim -30^\circ\text{C}$, it is recommended to use 99% (mass fraction) ethanol.

Warning: Ethanol is flammable, pay attention to fire prevention and ventilation!

4. Ethanol explosion limit: 3.5%~18.0% (volume); opening flash point: 13°C

5. The user can choose the proper refrigerant according to his needs.

6. It is strictly forbidden to use brine ($\text{KCl}/\text{H}_2\text{O}$, $\text{NaCl}/\text{H}_2\text{O}$, $\text{CaCl}_2/\text{H}_2\text{O}$) as the refrigerant.

7. The coolant should not corrode stainless steel, chromium, and silicone rubber materials.

3.2 Power connection

The power supply shall be provided according to the power nature required in the equipment nameplate and shall meet the following requirements:

1. The power supply must be reliably grounded.

(a) A closed type low temperature coolant circulation pump using single-phase power supply. The power supply provided by the user shall be single-phase two-wire system. (L, N, PE).

(b) A closed type low temperature coolant circulation pump using a three-phase power supply shall be supplied by the user with a single phase four wire system. (L₁, L₂, L₃, N, PE).

2. The phase sequence protector of the closed type low temperature coolant circulation pump using three-phase power supply should be consistent with the requirements of the closed type low temperature coolant circulation pump. Otherwise, the machine cannot be started normally. At this point, you only need to exchange the connection of any two phase lines.

Note:

If the power supply is not properly connected as described in 3.2, resulting in electric shock or equipment damage, the user shall bear the responsibility.

3.3 Control panel operation

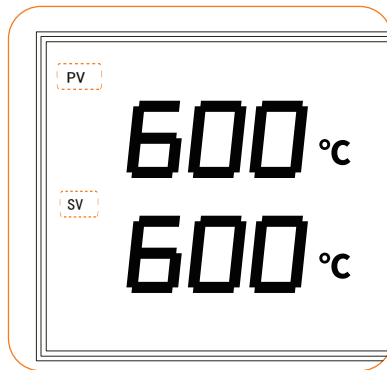

1. After the controller is powered on, the upper display PV displays the "temperature measurement value" and the lower SV displays the "temperature setting value" for about 3 seconds, and then enters the normal display state.

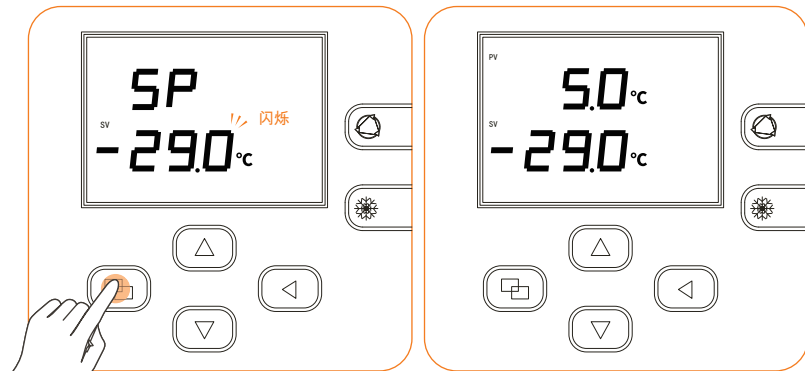

2. Click the "Set" button to enter the temperature setting state, the upper row of the display window displays the prompt "SP", the lower row SV displays the temperature setting value, you can use the increase and decrease buttons, shift button (moving flashing Digital position) to the desired setting value; then click the "Set" button to exit this setting state, the setting value is automatically saved.

*In the setting state, if no key is pressed within 1 minute, the controller will automatically return to the normal display state, and the setting parameters are not saved.

Figure3.3.1

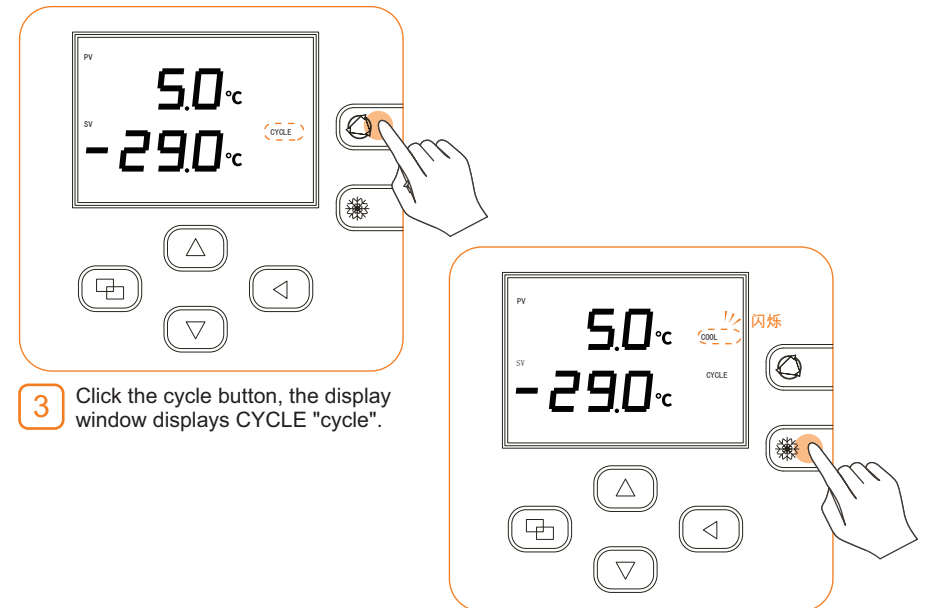

3. Click the cycle button, the display window displays CYCLE "cycle".

4. Click the cooling button, the display window displays COOL "cooling" and flashes, with a delay of 3-4 minutes After starting work.

Figure3.3.2

3.4 Communication connection (can connect 32 controllers of this series at the same time)

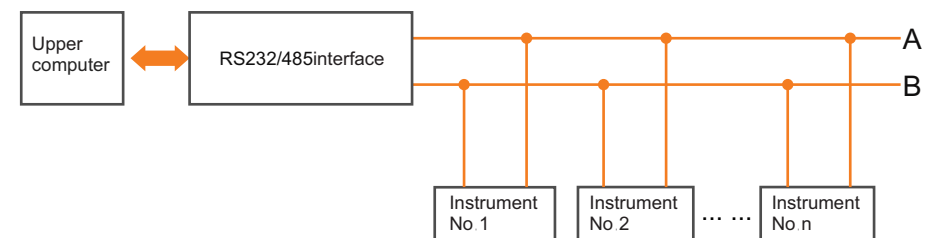

Figure3.4.1

3.5 Wiring diagram

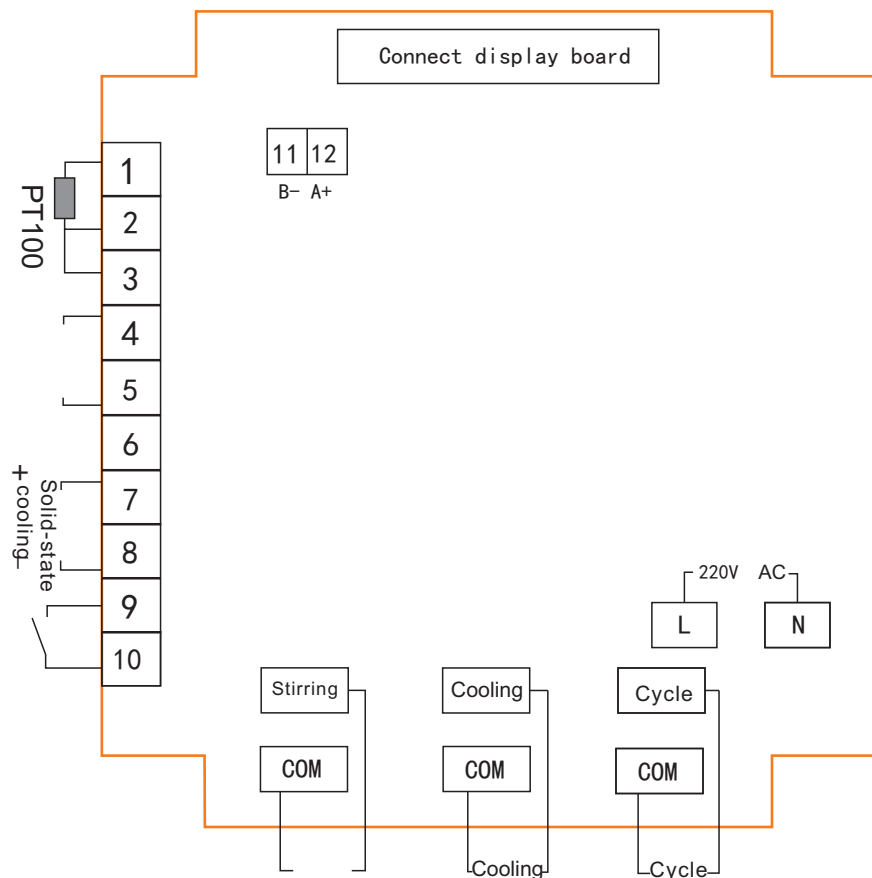
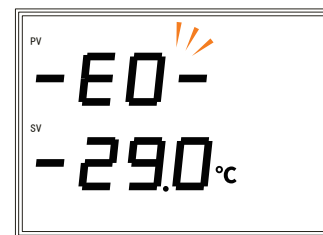
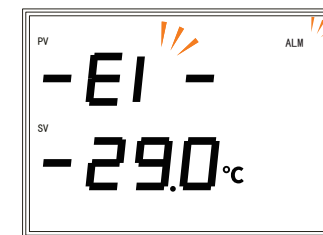

Figure3.5.1

3.6 The error displaying



Temperature sensor is faulty or out of range. The buzzer sounds and the PV window flashes "-E0-"



When the over-temperature alarm occurs, the buzzer will sound and the "ALM" alarm lamp will be on, and the PV window will flash "-E1-"

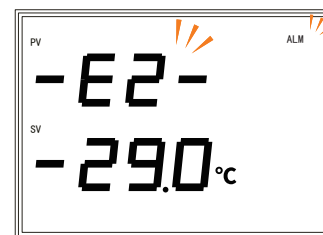

When the temperature is low, the buzzer beeps and the "ALM" alarm light is on, and the PV window flashes "-E2-"

- When the buzzer sounds, you can press the decrease key to mute the sound. In the setting state, if no key is pressed within 1 minute, the controller will automatically return to the normal display state, and the setting parameters will not be saved.

Figure3.6.1

4 Maintenance and management

In order to make the equipment run normally and prolong the service life, please do daily maintenance and management. Before maintenance, please disconnect the power supply of the equipment, prepare tools and materials, and start work according to the requirements of this instruction manual. Otherwise, electric shock or equipment damage may occur.

4.1 Management

1. Please wipe the surface of the machine with a soft cloth frequently to keep it clean. Do not rinse directly with water!
2. Except for the circulation system, it is forbidden to enter the liquid in other parts of the sealed low-temperature coolant circulation pump.
3. Do not use brushes, abrasive powders, acid, gasoline or other solvents to clean the surface of the body to avoid damage to the protective layer.
4. The liquid storage tank must be dried after cleaning to avoid contamination of the refrigerant when it is used next time.
5. Frequently check the connecting pipes of the equipment, and if it is found to be aging or damaged, replace it according to the original specifications in time.

4.2 Maintenance of cooling system

To maintain the cooling effect, please clean the heat sink regularly, the steps are as follows:

- (1). Power off the device
- (2). Open the door
- (3). Clean the dust on the heat sink (it is recommended to use a vacuum cleaner or a soft brush to handle in the direction)

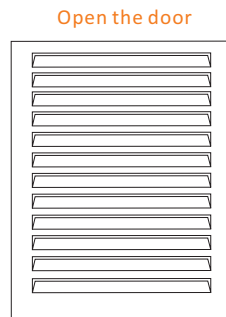

Figure4.2.1

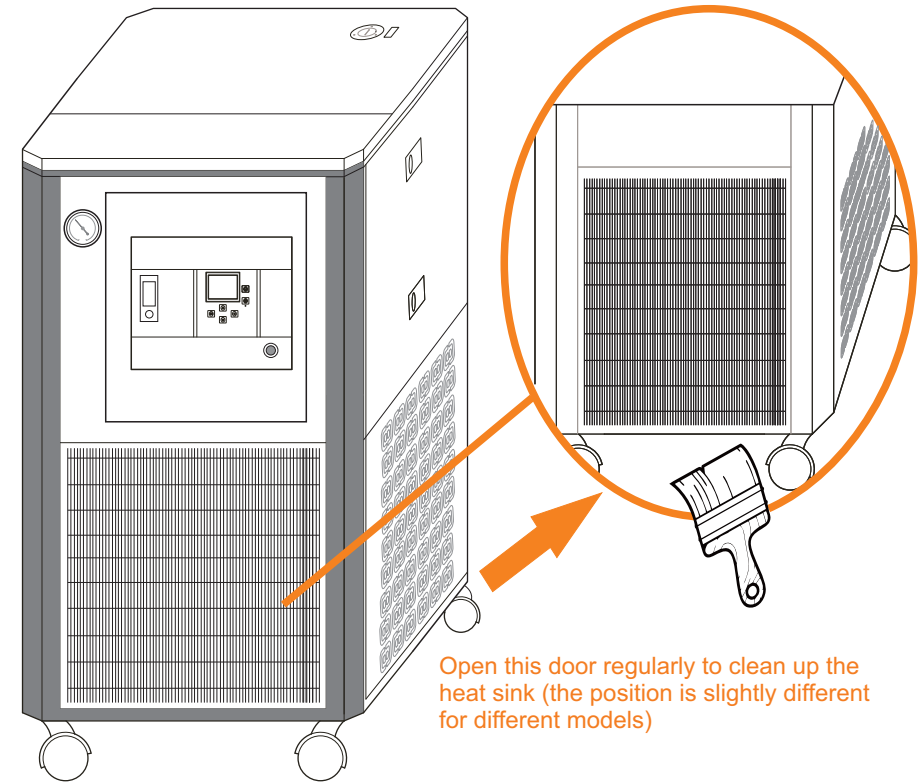

Figure4.2.2

4.3 Maintenance requirements

1. Equipment maintenance must be undertaken by professional technical personnel or personnel authorized by our company;

2. If the equipment needs to be returned to the factory for repair, please contact our company;

3. Before the equipment is returned to the factory for repair:

(A) Ask the user to release all the refrigerant in the circulation system;

(B) Please fill in the fault information record in detail and feed it back to the company;

(C) Please add safety packaging to the equipment to avoid damage to the equipment due to vibration and collision during transportation.

5 Parameters

Table 5.1 Technical parameter of sealed low-temperature coolant circulation pump

Model	DLSB-10/30	DLSB-10/40	DLSB-10/80	DLSB-10/120
Tank Volume(L)	7L			
No load minimum temperature(°C)	-30°C~30°C	-40°C~30°C	-80°C~30°C	-120°C~30°C
Cooling capacity (W)	2010-650	2800-550	3650-950	4380-550
Flow (L/min)	25			
Head H (m)	8			
Voltage(V)	220			
Current(A)	5.2	5.8	10	16
Power (W)	1000	1300	2500	3600
Cold tank size(mm)	160*310			
Length*width*height (mm)	620*540*920		810*710*1240	970*800*1245

Table 5.2 Technical parameter of sealed low-temperature coolant circulation pump

Model	DLSB-20/30	DLSB-20/40	DLSB-20/80	DLSB-20/120
Tank Volume(L)	10L			
No load minimum temperature(°C)	-30°C~30°C	-40°C~30°C	-80°C~30°C	-120°C~30°C
Cooling capacity (W)	2800-600	7300-1200	8760-950	9000-550
Flow (L/min)	25			
Head H (m)	8			
Voltage(V)	220	380		
Current(A)	6.3	7	12	18
Power (W)	1300	3200	6000	9500
Cold tank size(mm)	160*310	200*350		
Length*width*height (mm)	620*540*920	710*580*1050	810*710*1240	970*800*1245

Table 5.3 Technical parameter of sealed low-temperature coolant circulation pump

Model	DLSB-30/30	DLSB-30/40	DLSB-30/80	DLSB-30/120
Tank Volume(L)	17L			
No load minimum temperature(°C)	-30°C~30°C	-40°C~30°C	-80°C~30°C	-120°C~30°C
Cooling capacity (W)	4600-600	7300-900	8760-950	9000-550
Flow (L/min)	25			
Head H (m)	8			
Voltage(V)	220	380		
Current(A)	11	7	12	18
Power (W)	2100	3200	6000	9500
Cold tank size(mm)	200*350			
Length*width*height (mm)	710*580*1050		810*710*1240	970*800*1245

Table 5.4 Technical parameter of sealed low-temperature coolant circulation pump

Model	DLSB-50/20	DLSB-50/30	DLSB-50/40	DLSB-50/80	DLSB-50/120
Tank Volume(L)	17L				
No load minimum temperature(°C)	-20°C-30°C	-30°C-30°C	-40°C-30°C	-80°C-30°C	-120°C-30°C
Cooling capacity (W)	6300-900	10500-900	12775-650	15330-550	15750-550
Flow (L/min)	35				
Head H (m)	12				
Voltage(V)	220	380			
Current(A)	10	8	11	22	32
Power (W)	2500	4000	5500	10800	
Cold tank size(mm)	250*370				
Length*width*height (mm)	770*670*1180		970*800*1245	1500*960*1300	

Table 5.5 Technical parameter of sealed low-temperature coolant circulation pump

Model	DLSB-100/30	DLSB-100/40	DLSB-100/80	DLSB-100/120
Tank Volume(L)	35L			
No load minimum temperature(°C)	-30°C-30°C	-40°C-30°C	-80°C-30°C	-120°C-30°C
Cooling capacity (W)	15330-550			15750-600
Flow (L/min)	35			
Head H (m)	12			
Voltage(V)	380			
Current(A)	14			32
Power (W)	5800			16110
Cold tank size(mm)	300*350			
Length*width*height (mm)	970*800*1350			1500*960*1500

6 Common fault analysis reasons and treatment

faults phenomenon	Cause of faults	Treatment measures
NC table is not obvious	No power	Find out if the power cord is well connected or loose
PV shows" □□□□"	Defective sensor	Repair or replace
Not cooling	Check whether the thermostat is set correctly, whether the compressor is working, whether the AC contactor is damaged, and whether the refrigerator is seriously leaking.	Reset the thermostat parameters, repair or replace the AC contactor, search for leaks, and refill the refrigerant after repair
Cooling slowly	Check whether the refrigerant used is sticky and thick, whether the condenser fan is normal, whether the condenser screen is too dusty, whether the refrigerant is leaking, and whether the system is blocked by oil or ice.	Replace the refrigerant (the freezing point of the refrigerant should be <-85°C, the boiling point should be >50°C). Repair or replace the motor, find the cause of the leakage and refill the refrigerant, thoroughly remove the dust on the condenser filter, check the oil separator, Whether there is a problem with the capillary tube, filter drier, expansion valve, etc. repair or replace
Noise loudly	There are loose parts inside the machine	Re-tighten the fixing screws of compressor, fan, condenser, etc.
Not circulating	There is problem with the circulating pump system	Dredge the system to repair or replace the circulating pump

7 Precautions

Read the precautions carefully before using the instrument.

Power supply

The power supply of this machine must use standard 220V or 380V. It should have a reasonable grounding system and be equipped with three-level standard safety sockets. Except for the plugs provided by our factory, all other plugs must not be connected externally, please use the air switch!

Medium

Please use ethanol or methanol as medium, do not put sand or debris into the cooling system or circulation pump to prevent blockage.

Line connection

Please use a three-phase power supply to prevent the host from being burned by wrong wiring. If you do not understand, please consult the seller in time.

Ventilation protection

There are heat dissipation holes around the instrument. There should be enough space to prevent dust. The instrument should be placed away from heating equipment and avoid direct sunlight.

Temperature and humidity

The normal working room temperature range of this instrument is $\leq 25^{\circ}\text{C}$, and the humidity range is $\leq 60\%$. Exceeding this range will affect the safety performance and use performance of this instrument.

Instrument movement

It is strictly forbidden to move or tilt the instrument arbitrarily after filling the liquid in storage tank. The liquid in the tank may flow into the machine inside and cause danger or damage the machine. Indoor fire is also strictly prohibited.

Maintenance service

Do not open or repair the instrument without authorization, as it may cause more damage. In case of error, professional technicians should come to repair.

Special attention

Please clean the vents of the condenser in time when using this instrument to prevent blockage and avoid damage to the compressor due to excessive temperature.

8 Warranty statement

1. Free service period: within 12 months from the date of purchase, the product can be repaired freely if it fails due to quality reasons.

2. During the prescribed warranty period, those who have one of the following conditions will not be entitled to free maintenance.

(A) No warranty card or proof of purchase;

(B) If the equipment is damaged due to improper use by the user, it is not within the scope of free service.

(C) Caused by failure to install and use according to the requirements of the instruction manual and the equipment;

(D) Such as failure or damage caused by transportation, movement, falling and bumping;

(E) Failures and damages caused by the product after transformation;

(F) Failures and damages caused by force majeure such as fire, earthquake, flood and wind disasters and abnormal power supply;

(G) Consumption, wear, aging and replacement of consumables.

3. After the expiration of the free service or maintenance beyond the scope of the free service, the company will charge a maintenance fee.

4. When there is a problem with the equipment, please contact the after-sales service personnel in time.

This instruction manual is subject to change without notice.